

# BLE\* Module Specification

Model: MS50SFA

Version: V2.0

\* Low energy Bluetooth 4.0 and above

- 1) The *Bluetooth* trade mark is owned by the *Bluetooth* SIG Inc. USA.
- 2) All other trademarks listed herein are owned by their respective owners.
- 3) All specifications are subject to change without notice.

## Overview

The MS50SFB is a compact and very small size Bluetooth 5.0 module with ultra-low power consumption and optional antenna types; it is very suitable for the coin cell battery powered applications.

The module is highly integrated that contains all the necessary components from radio to different antenna and a completely implemented Bluetooth protocol stack and pre-flashed UART communication protocol.

## Features

- Frequency: 2402 to 2480 MHz
- Max. Output power: +4dBm
- Single power supply: 1.8 – 3.9V
- Range: 10-60 meters
- Chip: nRF52810 (Nordic)
- GPIO Quantity: 15
- 192kB Flash and 24kB RAM (nRF52810)
- Module size: 15.8 x 12.0 x 2.0 mm
- ARM Cortex-M4F processor
- Metal shielding with marking
- UART communication protocol (Slave / Master optional)
- 2 optional antenna types: PCB antenna, chip antenna
- Operating Temperature range: -25 to 85 degree Celsius



MS50SFA

## Certifications

- CE Certification
- FCC Certification (FCCID: 2ABU6-MS50SFA)

## Applications

- Cycle computer
- Heart rate monitor
- Blood pressure monitor
- Blood glucose meter
- Weighing machine
- Thermometer
- Mobile accessories
- Sports and fitness sensors
- Remote controllers / Toys
- Key fobs and wrist band
- 3D glasses and gaming controller

## 1. Pin Assignment and Description

### 1.1 Pin assignment

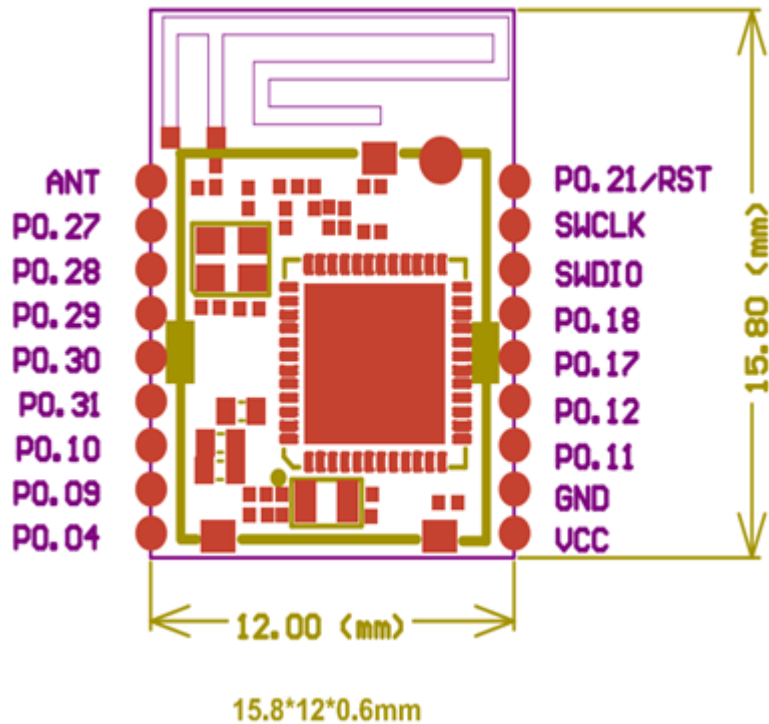

### 1.2 Pin description

Symbol	Type	Description
VCC	Power	Power supply
GND	Power	Ground
SWDIO	Digital I/O	System reset (active low). Hardware debug and flash programming I/O
SWCLK	Digital input	Hardware debug and flash programming I/O
P0.04 - P0.31	Digital I/O	General purpose I/O pin
ANT	Antenna	External antenna
RST	Digital I/O	Configurable as system RESET pin

## 2. Electronic Characteristic

### 2.1 Absolute maximum ratings

Symbol	Min	Max	Unit	Condition
VCC	1.7	3.9	V	Input DC voltage at VCC pin
ANT		+10	dBm	Input RF power at antenna pin at receiver

**Note:** The module is not protected against overvoltage or reserved voltages. If necessary, voltage spikes exceeding the power supply voltage specification must be limited to values within the specified boundaries by using appropriate protection devices.

### 2.2 Maximum ESD ratings

Parameter	Max	Unit	Remarks
ESD Sensitivity	4	KV	Human body model
	750	V	Charged device model
	+/- 8	KV	ESD indirect contact discharge

### 2.3 Operating temperature range

Parameter	Min	Max	Unit
Storage temperature	-40	85	°C
Operating temperature	-40	85	°C

### 2.4 Current consumption

Parameter	Min	Max	Unit	Remark
Receiving current		5.4	mA	standard mode
Transmission power		5.3	mA	transmission power at 0dbm
Sleeping current		1	uA	power mode 3

### 2.5 RF performance

Parameter	Min	Typical	Max	Unit
Receiver input sensitivity		-93		dBm
Output power	-30	0	+4	dBm

### 3. Physical Dimension

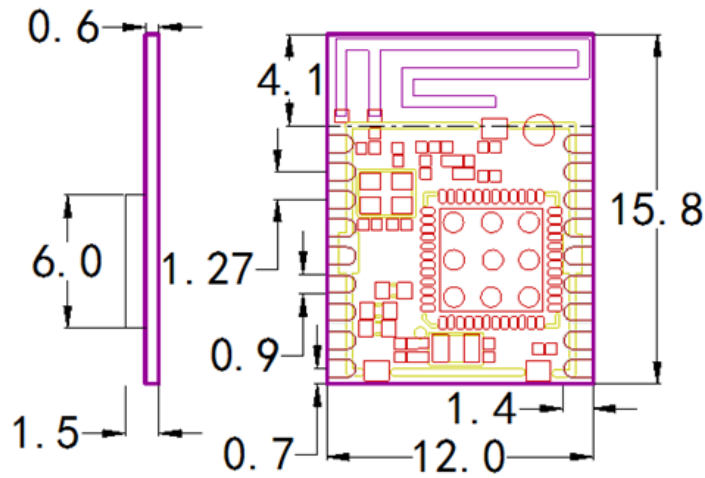

Unit: mm

### 4. Layout and Soldering Considerations

To make sure wireless performance is at its best condition, please layout the module on the carrier board as below instructions.

- 4.1 Carrier board under the antenna area of the module like the picture;
- 4.2 Keep out enough area for the antenna area;
- 4.3 Reflow profiles are to be selected according to standard manufacturing process;
- 4.4 The soldering temperature should be less than 206°C;
- 4.5 The module should be placed far away other low frequency and digital circuits;
- 4.6 The MS50 series modules contain highly sensitive electronic circuitry and are Electrostatic Sensitive Devices (ESD). Handling the MS50 series modules without proper ESD protection may destroy or damage them permanently.

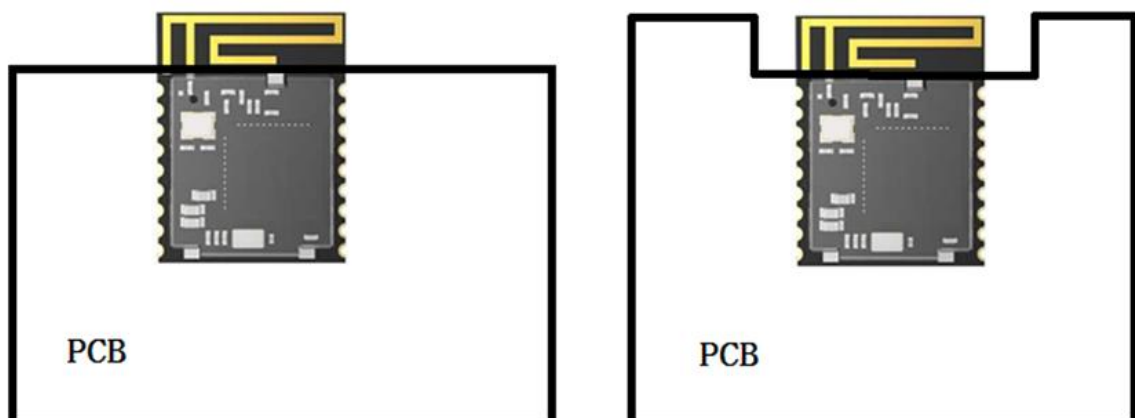

Recommended Layout for the Carrier Board

\*PCB: It's the mother board / carrier board.

## 5. UART Commands

Please refer to the UART commands document to know more.

## 6. Package

Details	Tray	Carton
Quantity (module)	80 pcs	4000 pcs / 50 trays
Net Weight	40.0g	4.5Kg
Gross Weight	75.0g	9.5Kg
Size	20 x 18 x 5 cm	32 x 23 x 40 cm

## 7. Ordering information

Ordering number	Description
306030058	MS50SFAC-003, nRF52810 BT 5.0 Module, PCB Antenna, UART function

<END>