

REV	DESCRIPTION	DRAWN	DATE

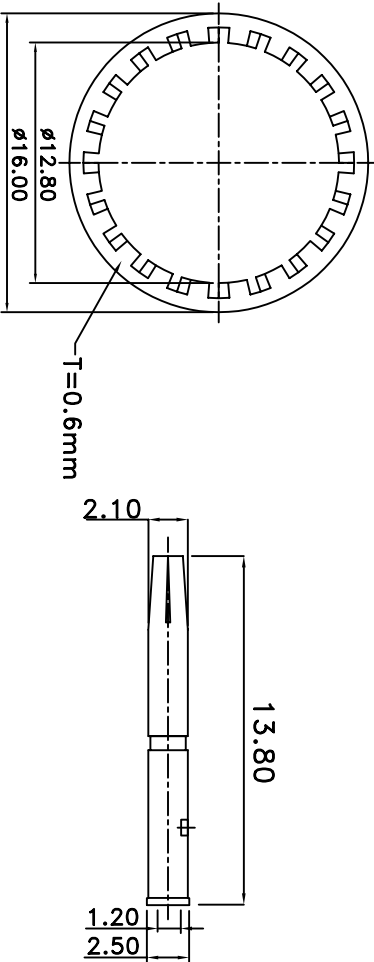
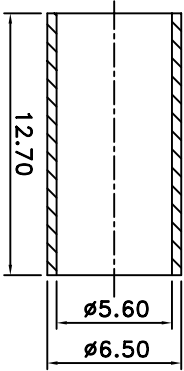
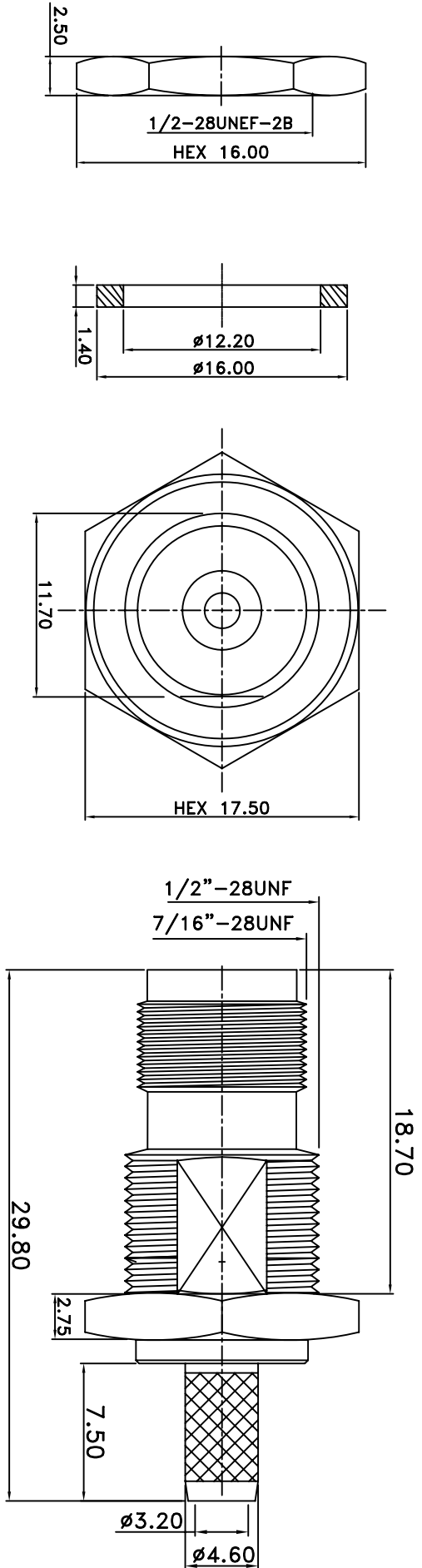

NO	Description	Qty	Material	Finish
8	NUT	1	BRASS	NICKEL
7	GASKET	2	RUBBER	BLACK
6	WASHER	1	BRASS	NICKEL
5	FERRULE	1	BRASS	NICKEL
4	PRESS FIT FERRULE	1	BRASS	NICKEL
3	DIELECTRIC	1	TEFLON	NONE
2	PIN	1	BRASS	GOLD
1	BODY	1	BRASS	NICKEL

UNLESS OTHERWISE SPECIFIED
 1. REMOVE ALL BURRS.
 2. BREAK ALL CORNERS & EDGES CO 15 MAX.
 3. CHAMFER 1ST & LAST THREADS 45°.
 4. DIAMETERS ON COMMON CENTERS.
 5. ALL DIMENSIONS ARE WITHIN 0.1 TYP. AFTER PLATING.

* MAJOR DIMENSION	UNLESS OTHERWISE NOTED TOLERANCES
0.5-6	±0.2
6-30	±0.4
30-120	±0.6
120-315	±1.0
ANGLES	±1°

SCALE	5/2	UNIT	MM	DRAWN	DATE	03/06/20
CHECKED						
DRAWN				andrew		

TITLE	DRAWING NO.	REV
TNC JACK BKD CRIMP FOR HDF200	TNC-18-03-F2-TGN	A
APPROVED	FILE NO.	