

Multifunction MiMo Antenna

L[G]AM-7-27-[X]24-58



Low Profile Design

MiMo 5G/4G/3G/2G + Single or 2x2 MiMo 2.4/ 5GHz

Optional GPS/GNSS

The L[G]PAM has a compact housing that contains 2x2 MiMo antenna function for 5G/4G/3G/2G and either single or 2x2 MiMo antenna function for 2.4/5GHz.

The LGAM version also includes an active antenna for GPS/GLONASS/Galileo/BeiDou with 26dB gain LNA.

This antenna range is ideal for vending machines, payment terminals and other M2M or IoT applications.



LPAM-7-27-24-58 shown

Technical Drawing

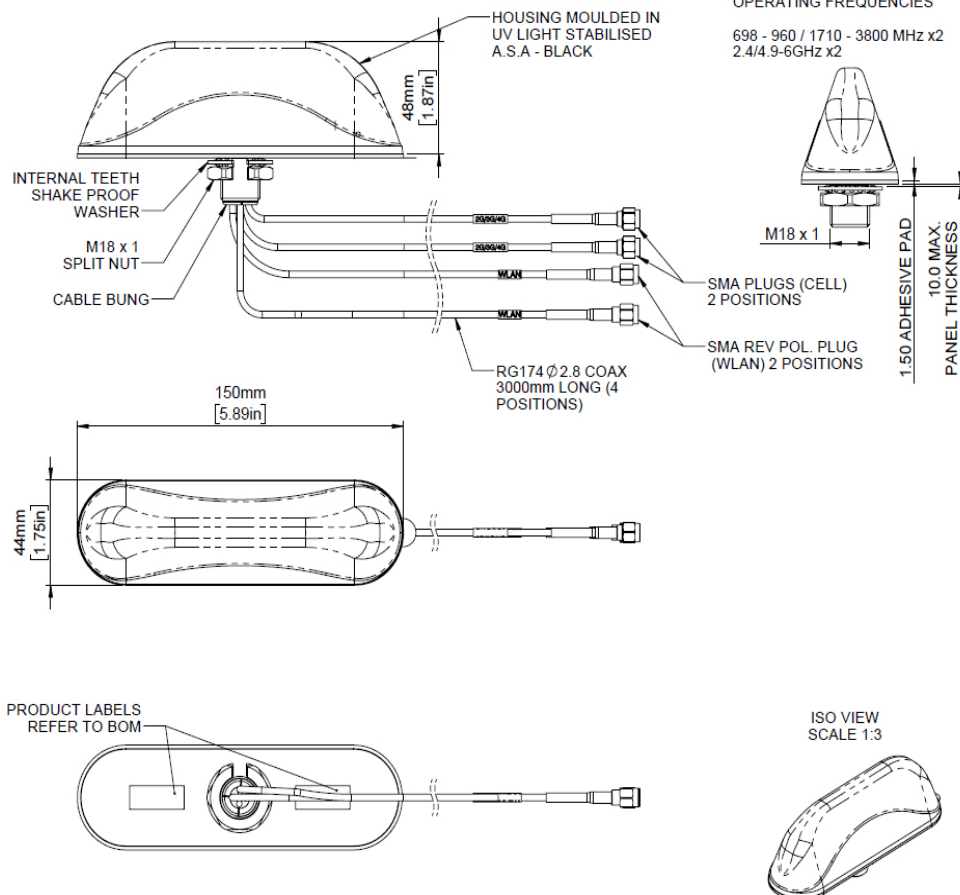

Multifunction MiMo Antenna

L[G]AM-7-27-[X]24-58

Product Data

Part No.		LPAM-7-27-24-58	LPAM-7-27-S24-58	LGAM-7-27-24-58	LGAM-7-27-S24-58
Electrical Data					
Frequency Range (MHz)	Element 1 (G Version)	1562-1612			
	Elements 2 & 3	698-960, 1710-2170, 2500-3800			
	Elements 4 & 5	2300-2500 & 4900-6000			
Operational Bands	Element 1 (G Version)	-	-	GPS/GNSS/Galileo/BeiDou	
	Elements 2 & 3	5G/4G/3G/2G			
		2x cell			
	Element 4 & 5	2.4 / 5.0GHz WiFi			
Peak gain: Isotropic*	Elements 2 & 3	2 x WiFi	1 x WiFi	2x WiFi	1x WiFi
	Elements 4 & 5	2dBi (698-960MHz) 5dBi (1710-3800MHz)			
Isolation <small>(with 5m (16') of RG174 cable)</small>	Cellular	>12dB			
	WiFi	> 20dB			
Typical Efficiency*	Elements 2 & 3	> 50%			
Correlation Co-efficient	Elements 2 & 3	<0.2			
Polarisation	Vertical				
Pattern	Omni-directional				
Impedance	50Ω				
Max Input Power (W)	Internal elements 25W				
GPS/GNSS Data					
Frequency Range (MHz)	1562-1612				
VSWR	<2:1 ± 4MHz				
Gain: LNA	26dB				
Polarisation	Right Hand Circular				
Operating Voltage	3-5V DC (fed via coax)				
Current	Typical <20mA				
Mechanical Data					
Dimensions (mm)	Total Height	50 (2.2")			
	Length	150 (5.9")			
	Width	44 (1.47")			
Operating Temp (°C)	-40° / +80°C (-40° / 176°F)				
Material	ASA				
Colour	Black				
Mounting Info					
Fixing	Panel Mount				
Hole Size (mm)	19 (3/4")				
Cable Data					
Cable Type - All Feeds		RG174			
Dimensions (mm)	Diameter	2.8 (0.11")			
	Length	3000 (10')			
	GPS/GNSS	-	-	SMA Plug	SMA Plug
Termination	2 x Cell	2 x SMA plug			
	WiFi	2 x SMA Rev Pol Plug	1 x SMA Rev Pol Plug	2 x SMA Rev Pol Plug	1 x SMA Rev Pol Plug

* without cable loss

Multifunction MiMo Antenna

L[G]AM-7-27-24[X]-58

Electrical Data

VSWR

Typical VSWR - 4G/3G/2G Elements 2&3*

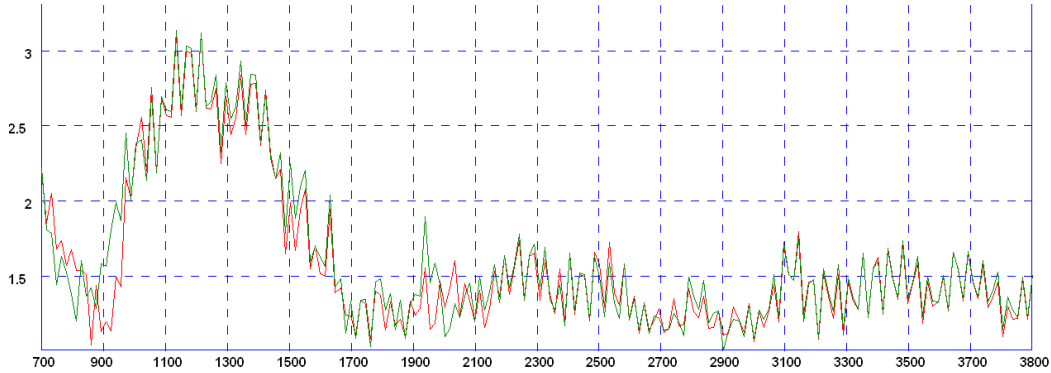

*VSWR measured with 3m (10') of RG174 cable a) Red: in free space b) Green: on a 400x 400mm (1'4') ground plane

Typical VSWR - WiFi Elements 4&5*

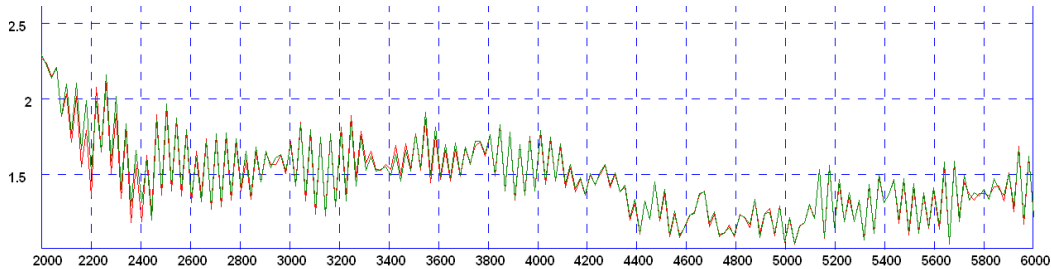

*VSWR measured with 3m (10') of RG174 cable a) Red: in free space b) Green: on a 400x 400mm (1'4') ground plane

Isolation

Typical Isolation - Cellular Elements 2&3*

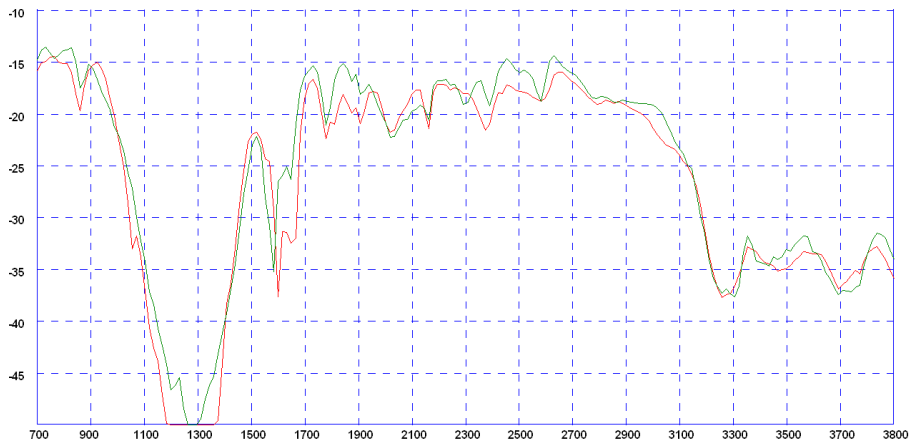

*Isolation measured with 3m (10') of RG174 cable a) Red: in free space b) Green: on a 400x 400mm (1'4') ground plane

Typical Isolation - WiFi Elements 4&5*

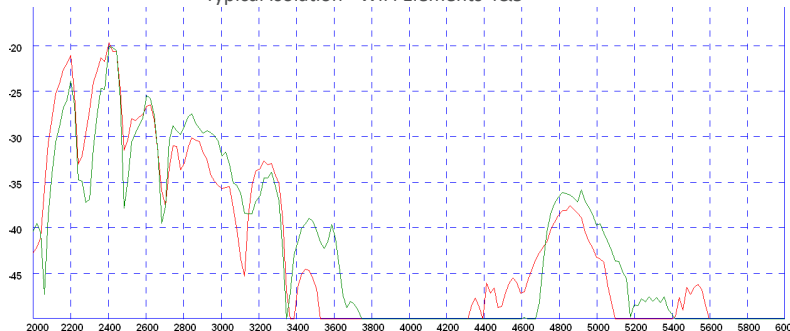

*Isolation measured with 3m (10') of RG174 cable a) Red: in free space b) Green: on a 400x 400mm (1'4') ground plane

Typical 3D Radiation Patterns - Cell / LTE Elements 2&3

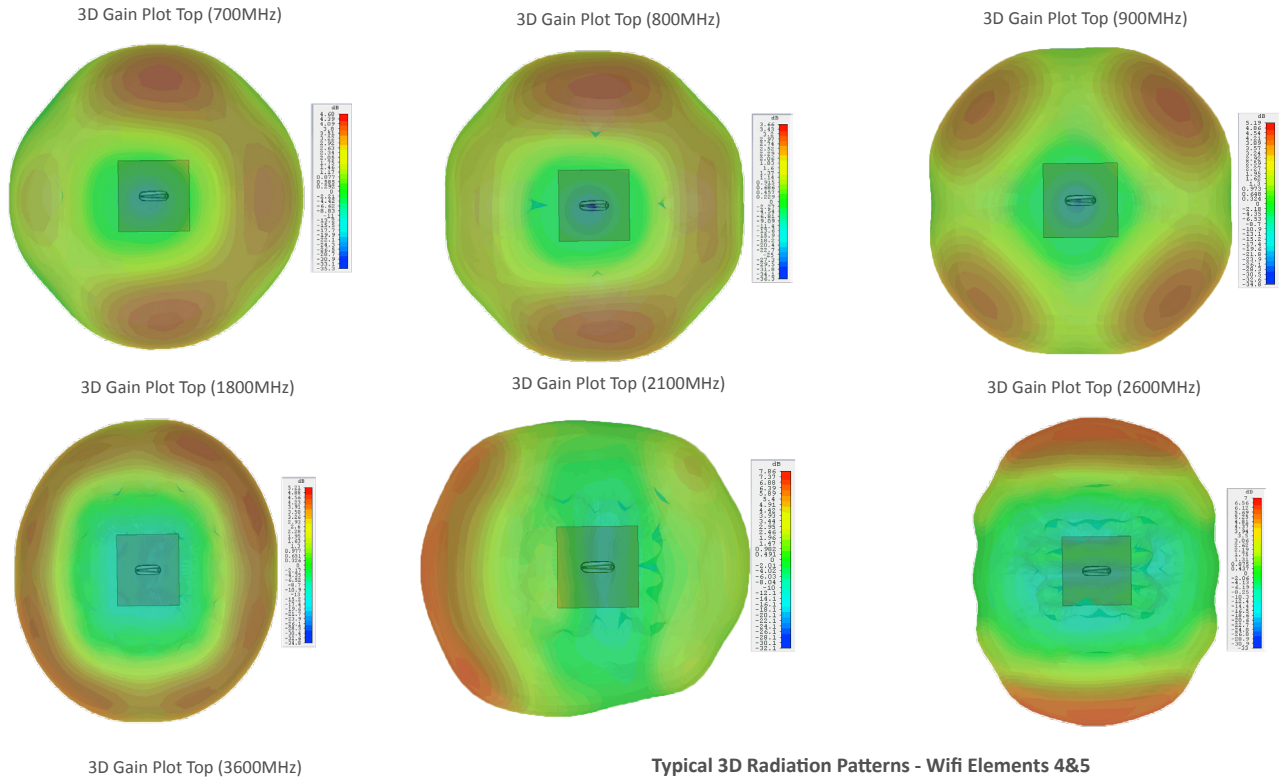

Typical 3D Radiation Patterns - Wifi Elements 4&5

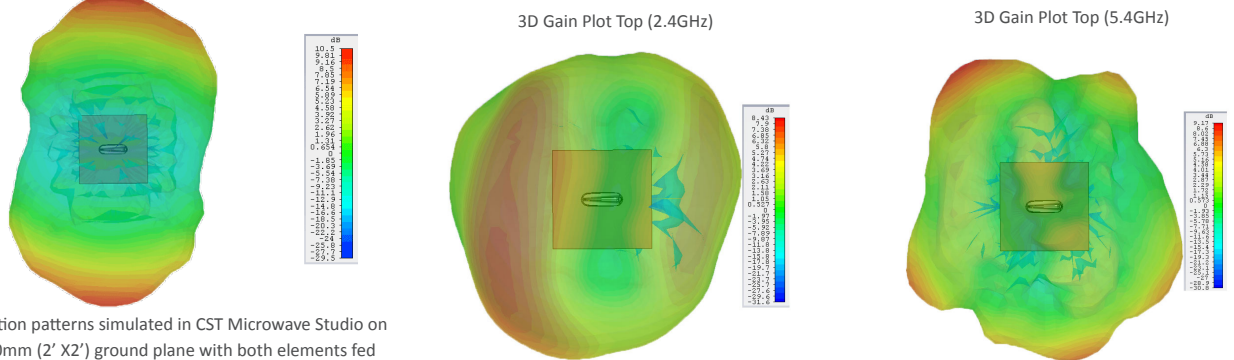

*3D radiation patterns simulated in CST Microwave Studio on a 600x600mm (2' X2') ground plane with both elements fed together.

Typical Radiation Patterns - GPS/GNSS Element 1

Element 3: Typical E Plane Pattern

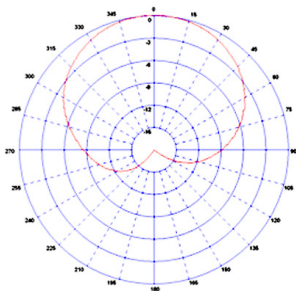

Typical 3D Radiation Patterns - Wifi Elements (Single Wifi)

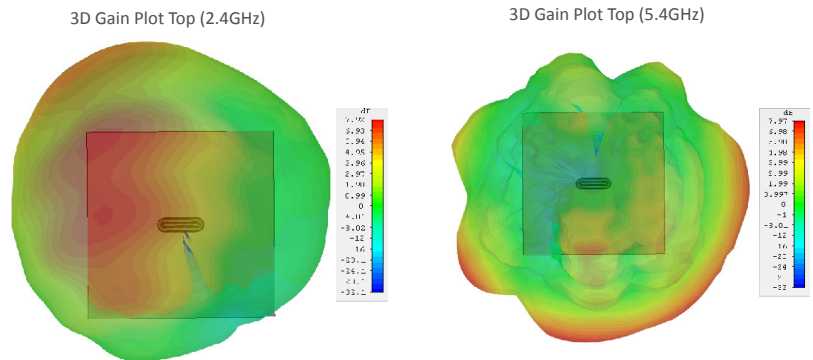

*3D radiation patterns simulated in CST Microwave Studio on a 600x600mm (2' X2') ground plane with a single element feed.