

Quick start guide UP Chassis - UPIH



Parts List

- One top cover with UP logo.
- One base case.
- Four (4) 2.5-5 machine screws.
- Four (4) 2.3-10 Sheet Metal Tapping screws.
- Two (2) 41-13 Rubber cover tap.
- One (1) 52-15 Rubber cover tap.

Not included with the kit, you may need to prepare:

- UP square board.
- UP extension board.
- Small screwdriver.

Assembly step

1. Start with placing the board into base bottom case and check well with the 4 sides exactly that match the I/O sides.
2. Take machine screws to fix the board first.
3. The top case covers the base bottom.
4. Take tapping screws, and holding the bottom base with board in place, feed the screws from the bottom, through the screw holes to the top cover feet, wiggling them a little bit to get them to line up.
5. Final step is click the rubber tap in suitable place.
6. Make sure they are finger tight, so they won't come undone during use.

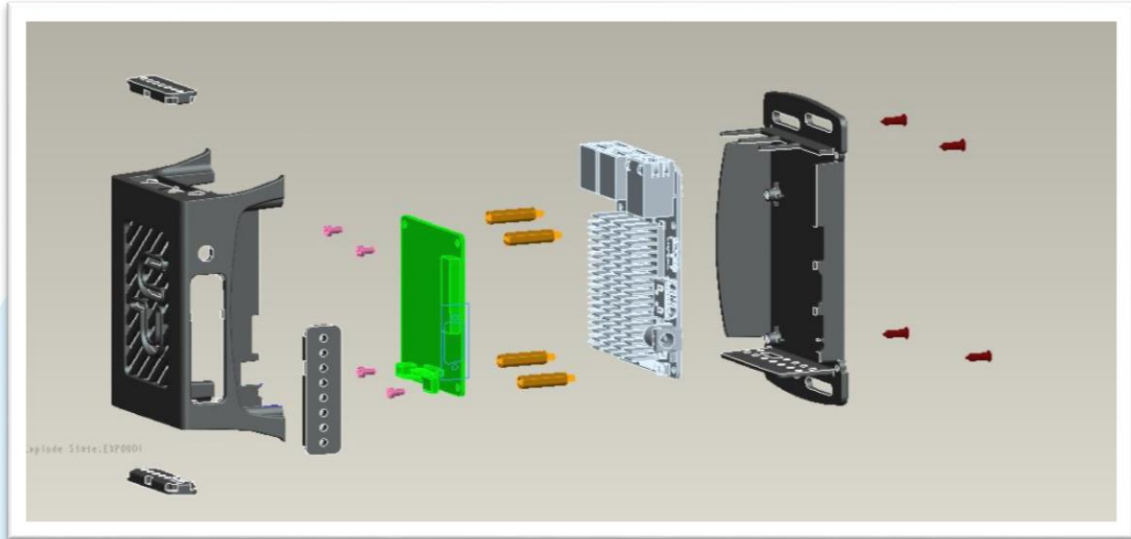

Exploded view on the chassis, including UP board and Extension board

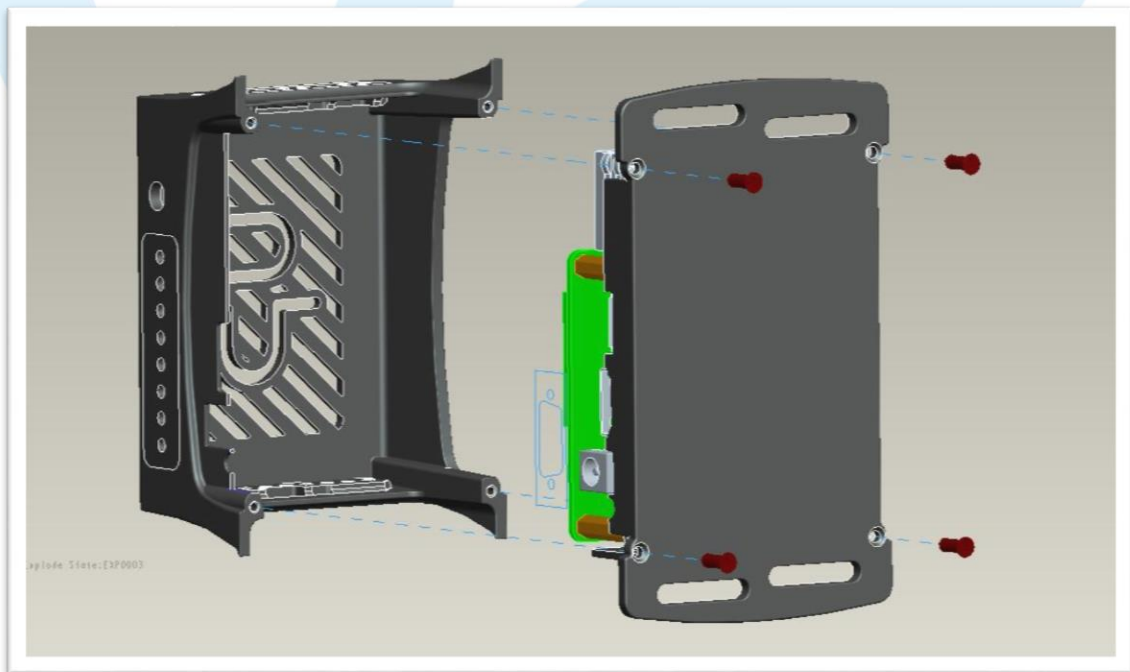

Screw location from the bottom view

As always, go check out up-community.org for support and more information about your UP board