



RNA

RNA - hybrid cabinet

Data module of hybrid cabinets
for home distribution systems. IP 20 / IK 05



■ Swing side panels

Side panels on both sides of the cabinet are folded for easy installation of mounted components. All removable and rotating parts are connected according to the standard.

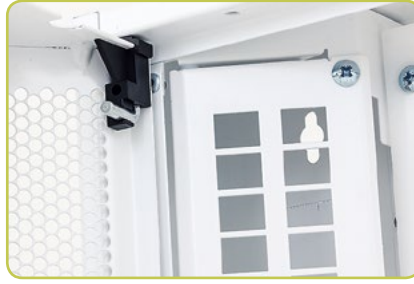

■ Data distribution

For the installation of data and communication distribution are prepared Keystone Standard modules in which easily fit any cables.



■ Power supply

On the opposite side of the data distribution system is preparation for the installation of the power system 230 V. According to the size of the cabinet there is a prepared opening for mounting classic sockets (with protective plastic box) and / or 10" 1U mounting opening extended for the possibility to install up to three common sockets.

■ Door construction

Plastic door panels and the entire structure support installation of WiFi devices.



Data cabinet is designed to accomplish all home cable distribution and installation of active elements. It is possible here to connect Internet, TV and satellite distribution systems, audio, as well as traditional telephone and ADSL connections.

Cable entries on the top, bottom and both sides of the cabinet allow it's mounting into larger assemblies with other cabinets of this series including power distribution cabinets. The doors of the cabinet are raised upward to ensure the necessary bending radius of the cables, including fiber cables. Perforation on the sides helps cooling of installed active elements. Installation of equipment with self-tapping screws on the inner plastic plate is quick and easy. Cabinets are supplied in modular height where one module occupies 166 mm. Power distribution cabinets of this series are in these modules as well. Width and depth of the cabinet is the same for all heights. The cabinet is universal for mounting on the wall or under the wall plaster. For installation in a recess in the wall is available a cover frame. **Thanks to the modularity can be used for example 2 modules high data part and 1 module electro, all covered with 3 modular frame.**

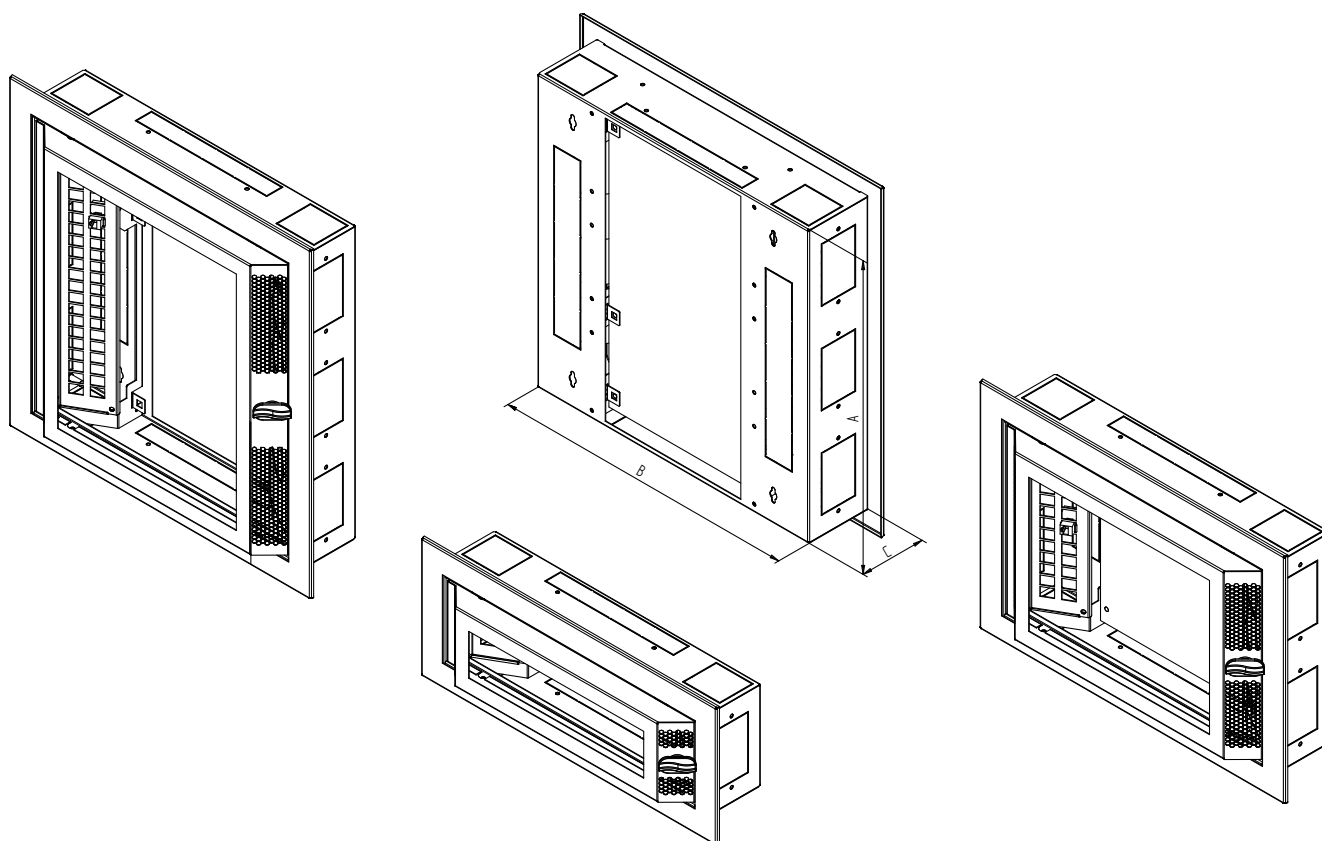

RNA

Type	Outer sizes (mm)			Span for hanging		Number of modules	Mounting plate w x h (mm)	10" mounting opening for sockets	Opening for sockets	Weight gross (kg)	Weight net (kg)
	A	B	C	R1	R2						
RNA-01-A51-YXX-X1	166	500	110	76	390	2 x 4	260 x 141	0	1	4,6	4,4
RNA-02-A51-YXX-X1	333	500	110	243	390	2 x 13	260 x 308	1	0	6,7	6,4
RNA-03-A51-YXX-X1	500	500	110	410	390	2 x 22	260 x 475	1	1	7	6,7

Recess for installation cabinet in the wall must be about 15-20 mm larger in each direction than the size of the cabinet. Usable depth of equipment is 110 mm.



■ Data distributions

There is a swing bearing panel with holes according to the most widely used Keystone Standard ready in the cabinet, for any data cabling termination - optical or metallic. All moving or detachable parts of the cabinet are interconnected according to standard.



■ Slide lock

The door of the cabinet are secured with a plastic slide lock which closes them securely against spontaneous and accidental opening and also allows easy operation of installed equipment.



■ Power supply

For mounting power distributions of 230 V, there is a separable panel available in every cabinet. This separable panel is designed for installation of classic sockets with protective plastic box. In larger cabinets it is possible to install even 10" distribution panel. In the flat door version it is only possible to use sockets called Legrand size - with the frontal panel size 45 x 45 mm.



■ Flat door version cabinet

Data cabinet RNA with the flat door (version -X2 in the end of the code) was developed for installation in places, where it is not possible to profit from the benefits of standard model of this cabinet. The total depth of this modified cabinet, including door, reaches only 110 mm. But using flat door brings some restrictions. The holder of the keystone for fitting data distributions is positioned upright to the plastic mounting plate, so the cables are interfering more to the space which is designed for installation active elements. Also, part which is specified (designed) for power supply distribution is different from the basic model. Because of the space restriction it is only possible to use sockets with the outside sizes 45 x 45 mm (called Legrand standard) without cover frame and the sockets are mounted on removable mounting panel. The possibility of using 10" power panel with the RNA-02 and RNA-03 types remained unchanged, as well as other properties of the basic version cabinet (mounting on/under the plaster, modularity etc.). The space for installation of the cartridge for optical welds in the space behind the plastic mounting plate meets the requirements of the relevant standards for the home installation.

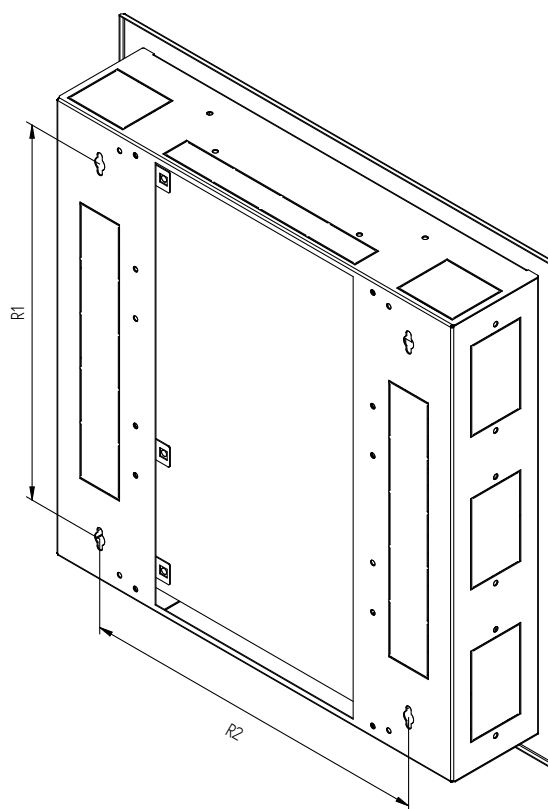
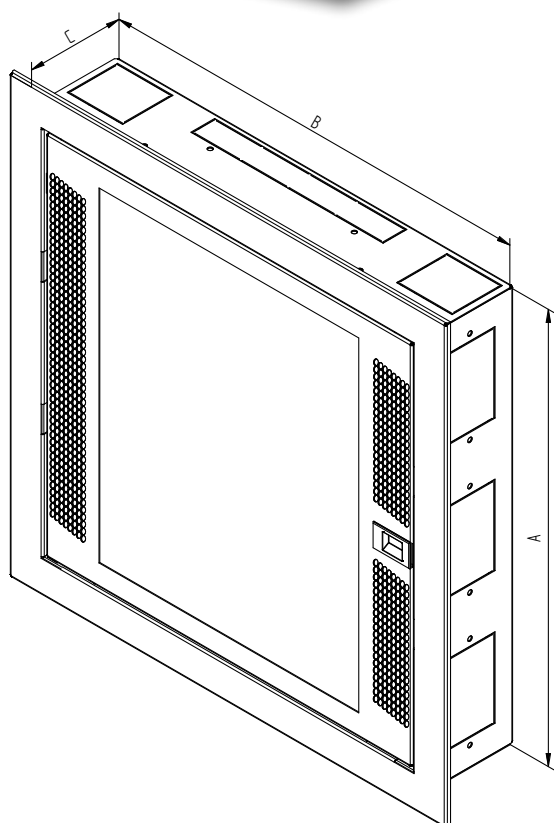

RNA - Flat door version cabinet

Type	Outer sizes (mm)			Span for hanging		Number of modules	Mounting plate w x h (mm)	10" mounting opening for sockets	Opening for sockets	Weight gross (kg)	Weight net (kg)
	A	B	C	R1	R2						
RNA-01-A51-YXX-X2	166	500	110	76	390	2 x 4	260 x 141	0	1	4,6	4,4
RNA-02-A51-YXX-X2	333	500	110	243	390	2 x 13	260 x 308	1	0	6,7	6,4
RNA-03-A51-YXX-X2	500	500	110	410	390	2 x 22	260 x 475	1	1	7	6,7

Recess for installation cabinet in the wall must be about 15-20mm larger in each direction than the size of the cabinet.
Usable depth of equipment is 80 mm.



Data cabinet RNA

■ Description, purpose of use

- IP 20 / IK 05
- Cabinet hangs directly on the wall or can be installed in a prepared recess in the wall.
- Cabinet is designed for individual assembly or with cabinet SNA.
- Multigate (cable openings) on the top, bottom and both side panels of the cabinet allow joining the cabinet into the larger sets with other cabinets of this series including an electrical cabinets SNA type.
- Cabinet construction:
 - welded frame from 1 mm thick sheet steel combined with plastic PEHD 8 mm.
 - frame door combined with steel of 1 mm thickness and plastic PP-H 1,5 mm.
- The frame of the cabinet and all the removable parts (side and rear covers, doors...) are bonded with patch cables that have to be properly fixed and inserted into connectors throughout the period of use of the cabinet.
- There is one M8 screw placed on the bottom part of the cabinet to connect the bonding.
- Cable openings covered with breakout-type blanking panels are placed in the top and the bottom of the cabinets, as well as on the sides.
- Maximum permissible load – cabinet: 20 kg; door: 2 kg.

■ Operating conditions

- Operating environment:
 - houses, private residences
 - cabinets are not intended for outdoor installation or installation in environments which could adversely affect the functionality of the cabinet and the equipment installed in it (such as an environment where there is a danger of explosions or a damp or humid environment)
- Must be protected against:
 - physical damage
 - improper handling
 - other uses than the one it was intended for
- Improper handling means primarily:
 - overloading (exceeding the maximum recommended loading capacity)
 - installing equipment which could adversely affect the operation and functionality of the cabinet or other installed devices
 - interference with the construction or design of the cabinet

■ Installation of the cabinet

- This type of cabinet hangs directly on the wall, held in place by screws, anchors and washers.
- Can be also installed in a prepared recess in a wall using standard construction methods.
- To ensure the maximum recommended loading capacity, it is necessary to fix the cabinet securely to a wall of corresponding capacity (brick, concrete or similar) and to install all equipment inside in such a way as to evenly spread out the weight of the equipment.

■ Environmental protection

- All parts are made of recyclable materials and after decommissioning the cabinet, it must be disposed of according to relevant regulations.

■ Certificate and conformity

- This product fully meets the standards of ČSN EN 62208 ed. 2 (357040), (EN 62208:2011), (idt IEC 62208:2011).

